



09 DIVISION
STUCCO

FIBER BASE COAT PREBLENDED STUCCO



Excellent Workability. Superior Production.

SPEC MIX® Fiber Base Coat (FBC) is a dry, preblended cement based stucco engineered with proprietary admixtures and fibers that are computer batched for consistency and performance unmatched by traditional field mixed stucco. SPEC MIX FBC has a custom blended sand gradation that increases the wall flexural strength while reducing cracking and crazing. The custom sand gradation also provides excellent workability and finishing properties for the applicator over a traditional field-mixed source.

Designed for both One Coat and traditional Scratch & Brown Coat systems, SPEC MIX FBC reduces shrinkage and increases long term durability and bond strength of the application. When gun or hand applied by a qualified applicator, SPEC MIX FBC is approved by Intertek as a one-hour fire rated wall when applied as a One Coat application, CCRR-0231. Submittals are available upon request for certification to applicable ASTM standards.

TYPICAL MATERIALS

PORTLAND CEMENT
HYDRATED LIME
PERFORMANCE ADMIXTURES
POLYESTER & FIBERGLASS FIBERS
ASTM C 897 AGGREGATE



(SU-05)



>> TAKE ADVANTAGE OF A SPEC MIX MATERIAL DELIVERY SYSTEM, THE ULTIMATE TOOL FOR INCREASED EFFICIENCY AND PRODUCTIVITY. EVERY TIME!

AT SPEC MIX®, STUCCO IS MORE THAN CEMENT AND SAND. IT'S INNOVATIVE PRODUCT ENGINEERING, IT'S QUALITY ASSURANCE, AND ABOVE ALL IT'S HIGH PRODUCT PERFORMANCE. EVERY TIME.

What separates SPEC MIX Fiber Base Coat from other stucco products is our international team of manufacturers providing sophisticated batching facilities ensuring SPEC MIX FBC's total product quality control. No matter if the project is a single-family home, multi-family complex or a commercial building, quality assurance and applicator satisfaction is our objective.

Raw material selection is another key to making SPEC MIX FBC the industry's top performing preblended stucco. SPEC MIX manufacturers consistently select and blend the finest raw materials available to eliminate contaminants entering the mixture that can lead to efflorescence, color variations, sagging and low strength. Because the quality of stucco sand varies from source to source, SPEC MIX product engineers uniquely focus on sands that comply with ASTM standards. Since the sand makes up as much as 70 percent of the final mix, using the best possible aggregates is imperative to manufacturing a high performance product. When the preblended SPEC MIX FBC is mixed and applied, the end result is a stucco wall with a tensile strength that reduces the risk of cracking and crazing in the system. As for application, the plasterer is equipped with a mix that provides superb workability and excellent finishing properties.

When contractors combine a SPEC MIX silo delivery system with SPEC MIX FBC stucco production on their job site, material quality and consistency, as well as the level of efficiency and productivity gained, cannot be equaled by traditional field-mixing methods. Unlike field-mixed stucco, there is no room for error with SPEC MIX FBC—just add water and mix as instructed, no other materials need to be added. While traditional field-mixing methods can lead to inconsistent product, testing issues, wasted labor and materials as well as poor productivity, the SPEC MIX system increases product quality, cuts waste and risk of back injury while improving material production by as much as 50 percent.

SPEC MIX is an innovator in preblended stucco development. For over 20 years SPEC MIX has led the preblended construction products industry with this type of innovation and by meeting these three objectives for all our professional products: Quality. Consistency. Efficiency. If the brand says SPEC MIX you are assured it delivers on all three.





Trusted Process. Unequaled Performance.

QUALITY STARTS WITH OUR PROCESS

The driving force behind our commitment to quality and our statement to the design community is: "What you specify is what you get!" Our process embraces our commitment to supply superior products. Quality control starts at the beginning of the material manufacturing process. That means it starts with the raw materials. The SPEC MIX quality control process requires that each raw material is pre-weighed and computer batched and blended for optimal consistency and field performance. Every batch of SPEC MIX FBC is produced using this unique production process. Only high quality local materials are selected. This process makes the optimum blend of material, and each mix constituent is required to meet ASTM standards. Our state of the art licensed manufacturing facilities ensure only designated formulation is packaged and delivered. Unlike field-mixed stucco, to validate our quality control, a digital printout displaying the actual proportions of materials in each batch may be kept as a permanent record by the contractor.



PRODUCTS THAT PERFORM

SPEC MIX Fiber Base Coat outperforms conventional stucco. The data shows it conclusively provides superior physical properties including: consistent compressive strength, reduced shrinkage as well as having increased flexural and tensile strength as a basecoat stucco. As a part of a system, SPEC MIX FBC successfully passed the rigorous requirements of ICC AC11 Acceptance Criteria for Cementitious Wall Coatings, as reflected in Intertek code compliance research report CCRR-0231. SPEC MIX FBC is flexible in its application and when used as a One Coat Stucco, it will reduce labor and scaffolding time and increase your efficiencies by reducing installation costs by as much as 50 percent. The physical properties and the workability of SPEC MIX FBC stucco, coupled with increased productivity using our silo systems ensures maximum system performance delivering material that's ready when you are.



SPEC MIX is product performance that performs on multiple levels. With manufacturing facilities located in every major market in the United States & Canada, local production means minimal shipping costs and timely delivery is readily available to your job site. SPEC MIX FBC is conveniently packaged in 80 lb (36.2 kg) bags as well as 3,000 lb (1,360.7 kg) recyclable bulk bags to be used with any of the SPEC MIX silo, power auger or continuous mix material delivery systems.

ENVIRONMENTALLY RESPONSIBLE.

AT SPEC MIX ENVIRONMENTAL STEWARDSHIP AND SUSTAINABILITY ARE THE KEYSTONES FOR THE WAY WE DEVELOP AND IMPLEMENT CEMENT BASED BUILDING MATERIALS AND MIXING SYSTEMS FOR THE CONSTRUCTION INDUSTRY. WE TAKE PRIDE IN HOW OUR SILO DELIVERY SYSTEMS AND PRODUCTS CONTRIBUTE TO LOWER THE IMPACT ON THE ENVIRONMENT IN THE DESIGN AND CONSTRUCTION OF ANY BUILDING.

OUR ONGOING GOAL IS TO SUPPORT ENHANCED ENVIRONMENTAL AND BIODIVERSITY MANAGEMENT. WE STRIVE TO STRENGTHEN REGIONAL ECONOMIES BY SUPPORTING LOCAL COMMUNITIES IN REDUCING FUEL CONSUMPTION AND AIR POLLUTION CAUSED BY TRANSPORTING BUILDING MATERIALS LONG DISTANCES.

WITH MORE THAN 60 MANUFACTURING FACILITIES, THE SPEC MIX ORGANIZATION IS POSITIONED TO SERVICE EVERY MAJOR MARKET THROUGHOUT NORTH AMERICA WITH FACTORY PREBLENDED, HIGH PERFORMANCE MASONRY MORTARS, GROUT, STUCCO BASECOATS, AND SHOTCRETE.

SPEC MIX IS YOUR FIRST SOURCE TO LOOK AT WHEN YOU WANT YOUR PROJECT TO BE LEED™ CERTIFIED. CONSULT WITH US OR YOUR LOCAL SPEC MIX REPRESENTATIVE TO FIND OUT MORE ON HOW SPEC MIX CONTRIBUTES TO AN EARTH FRIENDLY ENVIRONMENT.

PRODUCT TESTING AND PERFORMANCE

OUR ENGINEERS FOCUS ON SUPERIOR PRODUCT PERFORMANCE THROUGH CONSTANT RESEARCH AND DEVELOPMENT WHILE USING ADVANCED TECHNOLOGY AND MATERIAL CHEMISTRY TO DEVELOP HIGH QUALITY MATERIALS FOR BETTER WALL SYSTEMS. FOLLOWING THAT PROTOCOL, SPEC MIX FBC STUCCO IS DESIGNED TO BE A HIGH PERFORMANCE CEMENT STUCCO BASECOAT THAT INCORPORATES SHRINKAGE COMPENSATING AGENTS, A SUPERIOR BLEND OF POLYESTER AND FIBERGLASS FIBERS FORMULATED WITH AN OPTIMIZED SAND GRADATION THAT MEETS ICC SPECIFICATIONS. SPEC MIX FBC IS TESTED BY AN INDEPENDENT THIRD PARTY AS PART OF THE SPEC MIX QUALITY CONTROL PROGRAM AND ICC STANDARDS. THE RESULTS ARE AS FOLLOWS:

TRANSVERSE WIND LOAD (ASTM E 72)	AVG NEGATIVE PRESSURE: MAX LOAD AT 120 PSF AVG POSITIVE PRESSURE: MAX LOAD AT 180 PSF
ACCELERATED WEATHER (ASTM G 53)	PASSED TEST AT 2,000 HOURS OF EXPOSURE
ICBO ES FREEZE-THAW TEST (10 CYCLES)	PASSED TEST
ONE HOUR FIRE RATING (ASTM E 119)	PASSED TEST

THE OPTIMIZED SAND BLEND AND PROPRIETARY ADDITIVES GIVE SPEC MIX FIBER BASE COAT OUTSTANDING PLASTIC AND HARDENED PROPERTIES THAT OUTPERFORM STANDARD STUCCO.

SPEC MIX'S SPECIALIZED SAND GRADATION EQUALS SUPERIOR STUCCO

The quality, workability and durability standards for SPEC MIX Fiber Base Coat stucco starts with the special sand specification we demand. Only SPEC MIX utilizes an optimized sand gradation that combines calculated percentages of masonry sand and concrete sand to achieve an optimal gradation as show in the graphs and table to the right. To ensure the FBC stucco made from every production facility is top-quality, the aggregates from each SPEC MIX plant are analyzed and documented based on particle shape, composition, and gradation. Then the specific properties of the cementitious materials, special additives and fibers are analyzed to determine the proportions of each needed for the final mix design. This gives SPEC MIX the particular advantage of providing superior quality SPEC MIX FBC with minimal shipping costs compared to single or regional plant locations. As a result, the finished product can be hand troweled, spray applied, and finished by applicators with extreme efficiency while constructing a wall with shear strength, fire ratings, and toughness equivalent to conventional Three-Coat stucco systems.

To minimize shrinkage cracks of SPEC MIX FBC stucco, our engineers and lab technicians performed extensive field testing to verify this specialized sand gradation and formulation would outperform other stuccos—especially field-mixed stucco.

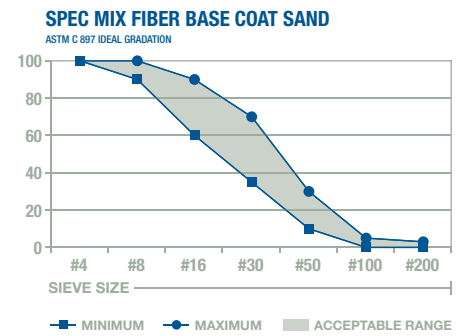
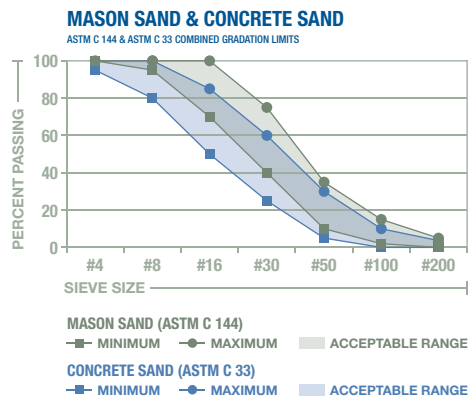

AGGREGATE / SAND SPECIFICATIONS

SIEVE SIZE	MASON SAND (ASTM C 144) PERCENT PASSING		CONCRETE SAND (ASTM C 33) PERCENT PASSING		FIBER BASE COAT (ASTM C 897) PERCENT PASSING	
	MIN	MAX	MIN	MAX	MIN	MAX
#4	100	100	95	100	100	100
#8	95	100	80	100	90	100
#16	70	100	50	85	60	90
#30	40	75	25	60	35	70
#50	10	35	5	30	10	30
#100	2	15	0	10	0	5
#200	0	5	0	3	0	3

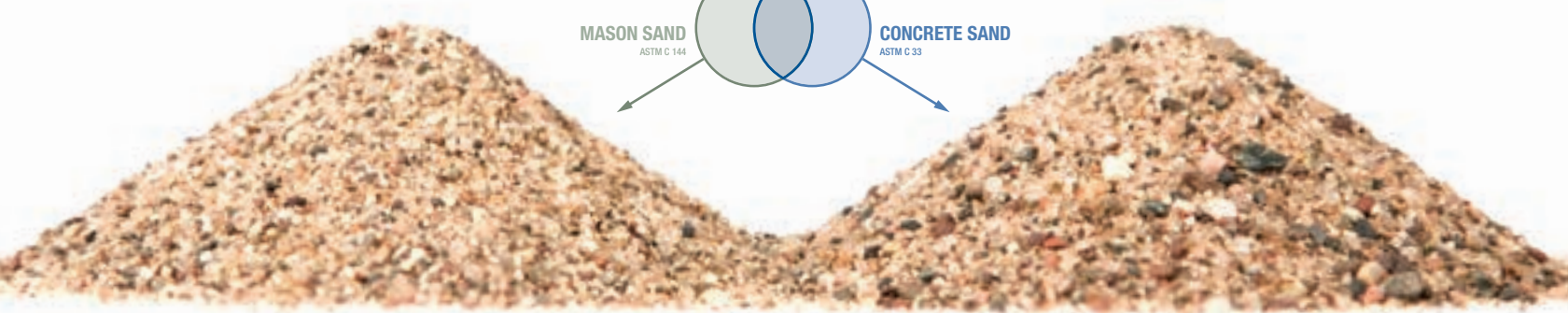
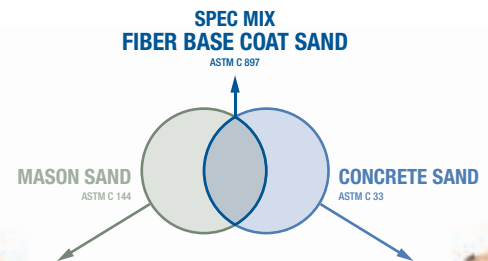

Applying SPEC MIX Fiber Base Coat

The proprietary formulation for SPEC MIX Fiber Base Coat stucco makes it the perfect solution for both One Coat wall systems as well as traditional Scratch & Brown Coat systems. When SPEC MIX FBC is properly applied by a qualified contractor and the architectural details are followed, this base coat stucco system is as durable as any exterior wall cladding system. Its hard surface resists abrasion and can withstand tremendous physical stress and weathering.

ONE COAT FRAMED STUD WALL APPLICATIONS

Framed Stud Wall Construction: SPEC MIX Fiber Base Coat stucco is designed to be applied in a single pass, or one coat, with a minimum thickness of 3/8 in (9.5 mm) and can be applied up to 1/2 in (13 mm) in one application in both commercial and residential construction. When SPEC MIX FBC is applied over exterior walls of wood or steel stud construction, The Intertek Report (CCR-0231) for SPEC MIX FBC specifies the stucco is tested and approved to be applied to substrates of (1) Wood based, such as plywood, Oriented Strand Board (OSB) or fiberboard, (2) Gypsum exterior grade sheathing, (3) Expanded Polystyrene (EPS) insulation tongue and groove board. When the wood based sheathing in the One Coat system is plywood, OSB, or asphalt impregnated, then a water resistant barrier (WRB) consisting of two layers of grade D building paper complying with current

UBC standards must be applied prior to the installation of self-furred wire fabric or self-furred metal lath. The wire fabric or metal lath used in this One Coat system must both comply with ASTM C 1032 or ASTM C 847 respectively, whereby the wire fabric shall be a minimum of No. 20 gauge, 1 in (25 mm) galvanized steel, woven fabric. In addition, the metal lath must be furred or self-furred and a minimum of 2.5 lb/yd. Both metal lath products must be installed in compliance with ASTM C 1063.

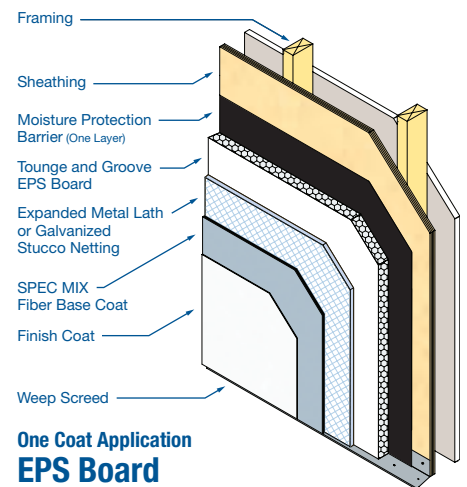
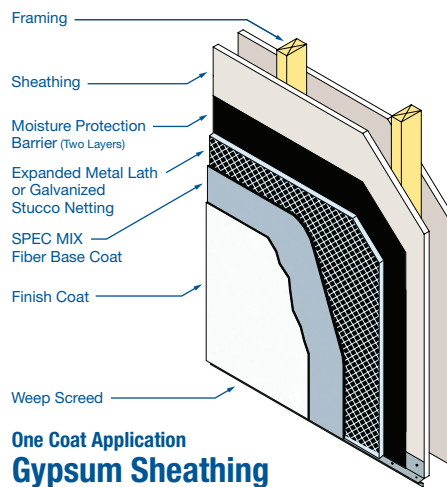
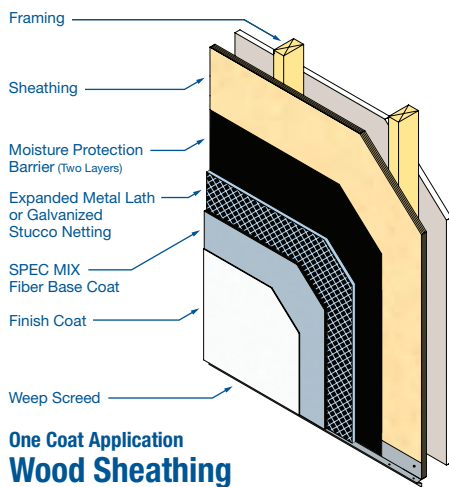

ONE COAT MASONRY APPLICATIONS

Masonry & Concrete Wall Construction: SPEC MIX Fiber Base Coat stucco is also engineered for wall systems with substrates such as concrete masonry units, cast in place concrete and precast concrete as well as natural stone. SPEC MIX FBC stucco and a finish coat over concrete masonry or concrete is a highly effective system for resisting water penetration into and through the walls. It should be installed in accordance with industry practices, and properly cured, to achieve its full potential. SPEC MIX FBC shall be applied directly to the prepared surface at a minimum thickness of 3/8 in (9.5 mm). In all circumstances, to achieve optimal adhesion the substrate must be clean and free of dust, oil, or other contaminants. In addition, the surface shall be conducive to good absorption and surface roughness to ensure proper bond. If surface roughness is insufficient, a bonding agent should be applied over the clean surface. When wire fabric or metal lath is specified, consult with the project architect and project engineer while following local building codes and standards.

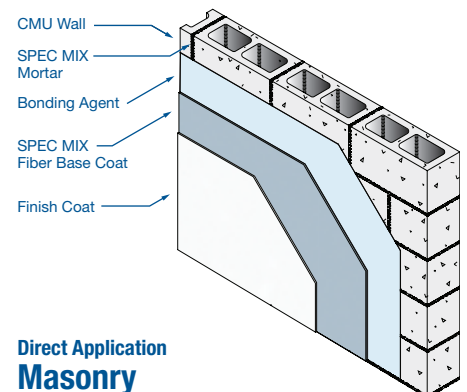

TRADITIONAL SCRATCH & BROWN COAT APPLICATIONS

Framed Stud Wall Construction: The versatility of SPEC MIX Fiber Base Coat stucco makes it an excellent product for Scratch & Brown Coat applications commonly referred to as “Traditional Stucco” or “Three Coat” systems. For this type of wall construction, SPEC MIX FBC is applied in two passes with the first application (Scratch Coat) being 3/8 in (9.5 mm) to 1/2 in (13 mm) (nominal thickness) and the second application (Brown Coat) 3/8 in (9.5 mm) to 1/2 in (13 mm) (nominal thickness). This applies to both commercial and residential construction. Similar to One Coat applications, in traditional Scratch & Brown Coat applications, SPEC MIX FBC is applied over exterior walls of wood or steel stud construction. Approved substrates are (1) Wood, such as plywood, Oriented Strand Board (OSB) or fiberboard, (2) Gypsum exterior grade sheathing, and (3) EPS insulation tongue and groove board.

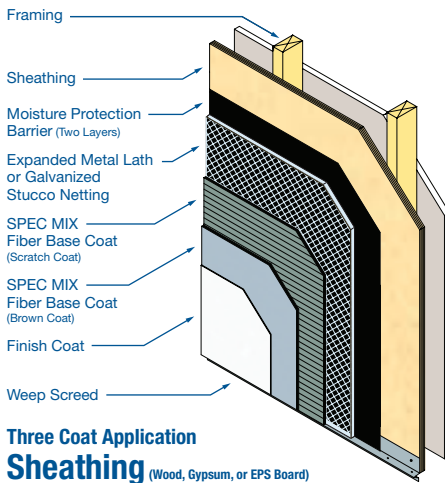

INSTALL EXPANSION AND CONTROL JOINTS TO PROPERLY ALLOW FOR MOVEMENT IN ANY STUCCO WALL SYSTEM; EXPANSION OR CONTROL JOINTS ARE REQUIRED AT LEAST AT EVERY 144 ft² (13 m²), WHERE DISSIMILAR MATERIALS ADJOIN, AS WELL AS FLOOR LINES IN MULTI LEVEL BUILDINGS, AND AT EXISTING JOINTS IN THE SUBSTRATE. IN EACH CASE, THESE JOINTS SHOULD ALWAYS BE INSTALLED IN ACCORDANCE WITH SPECIFICATIONS OF THE PROJECT ENGINEER, ARCHITECT, DESIGNER AND PROJECT DOCUMENTS.

CLIMATE & CURING

SPEC MIX FIBER BASE COAT STUCCO IS EITHER GUN APPLIED OR HAND-TROWEL APPLIED, IT MUST WET CURED FOR BEST OVERALL PERFORMANCE. NOTE THAT ALL CEMENTITIOUS STUCCOS REQUIRE MOISTURE TO CURE TO MINIMIZE CRACKING AND MAXIMIZE DURABILITY. FOR OPTIMAL INSTALLATION IN COLD AND WARM CLIMATES INCLUDING PROPER CURING PROCEDURES, FOLLOW PROJECT CONSTRUCTION DOCUMENTS AND NOTE THE INDUSTRY GUIDELINES BELOW.

- DURING THE APPLICATION AND CURING, SURFACE AND AMBIENT TEMPERATURES MUST BE BETWEEN 40 °F AND 100 °F (4 °C AND 38 °C). ALWAYS CONSULT YOUR LOCAL BUILDING CODE OFFICIALS FOR COLD-WEATHER CONSTRUCTION PRACTICES.
- DO NOT INSTALL STUCCO UNDER HOT, DRY OR WINDY CONDITIONS AND AVOID APPLYING SPEC MIX FBC IN DIRECT SUNLIGHT.
- BEFORE WET CURING, ALLOW SPEC MIX FBC STUCCO 2 TO 4 HOURS TO ACHIEVE ITS INITIAL SET (CLIMATE SENSITIVE).
- NEXT, MOIST CURE FOR 48 HOURS WITH REGULAR, CONSISTENT FOGGING SPRAY.
- PROTECT WALLS FROM RAIN, SNOW AND FROST FOR 48 TO 72 HOURS.

COVERAGE

DEPENDENT UPON SURFACE CONDITIONS, WORKMANSHIP AND TECHNIQUE AS WELL AS WASTE, SQUARE FOOT COVERAGE OF SPEC MIX FBC STUCCO MAY VARY. BELOW ARE ONLY ESTIMATES FOR 80 lb (36.2 kg) AND 3,000 lb (1,360.7 kg) COVERAGE RATES:

PACKAGE WEIGHT	FBC THICKNESS	COVERAGE
80 lb (36.2 kg)	3/8 in (9.5 mm)	20 to 24 ft ² (1.8 to 2.2 m ²)
80 lb (36.2 kg)	1/2 in (13 mm)	15 to 18 ft ² (1.4 to 1.7 m ²)
80 lb (36.2 kg)	3/4 in (19 mm)	10 to 12 ft ² (0.9 to 1.1 m ²)
3,000 lb (1360.7 kg)	3/8 in (9.5 mm)	750 to 900 ft ² (70 to 84 m ²)
3,000 lb (1360.7 kg)	1/2 in (13 mm)	560 to 675 ft ² (52 to 63 m ²)
3,000 lb (1360.7 kg)	3/4 in (19 mm)	375 to 450 ft ² (35 to 42 m ²)



The SPEC MIX PA4000 offers a low profile with high capacity that is easy to relocate on the job site.

SPEC MIX silo delivery systems are flexible to meet any jobsite demand.

Productivity and efficiency are directly related to the profitability of any project. SPEC MIX silo delivery systems are proven to increase jobsite productivity of an entire crew by making the material mixing station more efficient, no matter who is making product. SPEC MIX silo systems are engineered for simple and safe operation—all you need is a standard forklift to set up, charge and relocate the silo, using half the space of conventional mixing stations, but produce product twice as fast. Several silo designs are available to meet the stucco contractors' needs. From interior or exterior work, residential to commercial, large or small projects, there is a silo design to fit your needs. The weather resistant silos and product packaging allow all season construction, enabling you to remain productive year round.

Fast. Mobile. Clean. Safe.

Our mantra at SPEC MIX is “KEEP GOING. KEEP MOVING. KEEP WORKING.” With SPEC MIX silo systems on site, a contractor achieves maximum efficiency, which significantly speeds up production and reduces job costs. Our silo delivery systems range in size and capacity from 1 cubic yard (0.76 m³) units, 5 cubic yard (3.8 m³) units, and as much as 10 cubic yard (7.6 m³) units. Each is uniquely engineered to increase a contractor’s jobsite productivity and safety by making a laborer more efficient at the mixing station. All silos operate easily and smoothly, eliminating the heavy lifting and twisting standard with on-site batching of materials. Regardless of the project scope, SPEC MIX silo systems reduce the risk of inconsistent product, labor expense, material waste and back injury. As well, our silos and recyclable bulk bags protect our products from exposure to contaminants, weather, and debris to control efflorescence, color variation or other variables that could decrease the structural integrity of the stucco.

Space is a premium on most project sites. SPEC MIX silos are versatile and easily adapt to the diverse needs stucco contractors have working on any site. The portable silos and bulk bags require no special equipment—only a standard forklift to lift and dispense the 3,000 lb (1,360.7 kg) bulk bags or relocate the silo on site. Ranging in size from a 4' x 5' (1.2 m x 1.5 m) pallet sized footprint to an 8' x 11' (2.4 m x 3.4 m) footprint, SPEC MIX silos allow any contractor to use less space than traditional mixing stations. No space is required for large sand piles and numerous pallets of cement and lime. The dry, preblended material coupled with our unique silos allows work to continue through all seasons allowing stucco contractors to remain productive year round. No more frozen or water saturated sand piles that adversely affect product quality—just add water and pull the silo’s handle or turn on the power auger—it’s that easy. Now getting quality, consistent stucco is simple.



PA1000
GAS OR ELECTRIC



PA4000
GAS OR ELECTRIC



LOAD N GO



G7000



TEN BAGGER



SPLIT SILO





FIBER BASE COAT STUCCO (FBC)

SPEC MIX MAKES MIXING SIMPLE, EASY AND CONSISTENT. EVERY TIME.

Making SPEC MIX Fiber Base Coat from 80 lb (36.2 kg) bags or with our silo systems and 3,000 lb (1,360.7 kg) bags is simple and fast. All you need is a source of clean, potable water and a standard mechanical batch mixer. No matter what containment size the job requires, a contractor can make as little as a handful, or as much as a mixer full—the quality is always consistently high. There is no sand to shovel or bags to lift—just follow these steps.

80 lb (36.2 kg) BAG MIXING INSTRUCTIONS

WEAR IMPERVIOUS GLOVES, such as nitrile. Add approximately 1.2 to 1.5 gallons (4.5 to 5.7 liters) of clean water into the mixer for each 80 lb (36.2 kg) bag. Slowly pour the contents of the bag(s) into the mixer. Mix for 5 minutes until a firm, workable consistency is achieved. Avoid over mixing as this may affect the integrity of the finished product. If more water is needed, add small amounts at a time and continue to mix until the desired consistency is achieved. Do not exceed a total volume of 1.75 gallons (6.6 liters) of water for each 80 lb (36.2 kg) bag. Utilize the same mixing procedures throughout the project to maintain consistency. Prepare only as much mix as can be applied in one hour.

CURING: Moist curing is required for a minimum of 24 hours after coating application.

STORAGE: Material shall be stored off the ground and protected from rain and moisture at all times.

Keep mixing times and procedures the same every batch. Over mixing may entrain air, which can adversely affect plastic and hardened stucco properties.

SILO MIXING INSTRUCTIONS

WEAR IMPERVIOUS GLOVES, such as nitrile.

- 1 To start, to make any size batch, place 75% of the required water in the mixer.
- 2 For consistent results hand mixing is not recommended, only mechanical batch mixers ensure consistency, workability and good board life.
- 3 With the mixer running pull open the silo handle to dispense SPEC MIX FBC into the mixer.
- 4 Add the remaining amount of water for the desired consistency.
- 5 Mix the SPEC MIX FBC for 5 minutes.
- 6 Keep mixing times and procedures the same every batch. Over mixing may entrain air, which



COMPLIANCE WITH THE FOLLOWING CODES:

INTERTEK CODE COMPLIANCE RESEARCH REPORT (CCRR-0231) • INTERNATIONAL BUILDING CODE (IBC) • INTERNATIONAL RESIDENTIAL CODE (IRC) • BOCA NATIONAL BUILDING CODE 1999 (BNBC) • STANDARD BUILDING CODE (SBC) • UNIFORM BUILDING CODE (UBC)

APPLICABLE STANDARDS:

ASTM C 91 STANDARD SPECIFICATION FOR MASONRY CEMENT • ASTM C 109 STANDARD TEST METHOD FOR COMPRESSIVE STRENGTH OF HYDRAULIC CEMENT MORTARS • ASTM C 144 STANDARD SPECIFICATION FOR AGGREGATE FOR MASONRY MORTAR • ASTM C 150 STANDARD SPECIFICATION FOR PORTLAND CEMENT • ASTM C 207 STANDARD SPECIFICATION FOR HYDRATED LIME FOR MASONRY PURPOSES • ASTM C 595 STANDARD SPECIFICATION FOR BLENDED HYDRAULIC CEMENTS • ASTM C 897 STANDARD SPECIFICATION FOR AGGREGATE FOR JOB-MIXED PORTLAND CEMENT BASED PLASTER • ASTM C 926 STANDARD SPECIFICATION FOR APPLICATION OF PORTLAND CEMENT BASED PLASTER • ASTM C 979 STANDARD SPECIFICATION FOR PIGMENTS USED TO INTEGRALLY COLOR CONCRETE • ASTM C 1329 STANDARD SPECIFICATION FOR MORTAR CEMENT • ASTM C 1328 STANDARD SPECIFICATION FOR PLASTIC CEMENT • ASTM C 482 STANDARD TEST METHOD FOR BOND STRENGTH OF CERAMIC TILE TO PORTLAND CEMENT PASTE • ASTM C 666 STANDARD TEST METHOD FOR RESISTANCE OF CONCRETE TO RAPID FREEZING AND THAWING • ASTM C 190 STANDARD SPECIFICATION FOR TENSILE STRENGTH OF HYDRAULIC CEMENT MORTARS • ASTM C 348 STANDARD SPECIFICATION FOR FLEXURAL STRENGTH OF HYDRAULIC CEMENT MORTARS • ASTM E 514 WIND DRIVEN RAIN AVERAGE FLOW/WATER VAPOR PERMEABILITY

can adversely affect plastic and hardened stucco properties.

LIMITATIONS

SPEC MIX Fiber Base Coat Stucco should be installed in accordance with the provisions of the local building code and applicable ASTM standards. Good workmanship coupled with proper detailing and design assures durable, functional, watertight construction. Follow proper cold-weather and hot-weather application procedures at temperatures below 40 °F (4 °C) or above 100 °F (38 °C) respectively.

LIMITED WARRANTY

SPEC MIX, LLC warrants this product to be of **In the United States**

NOTICE: Obtain the applicable LIMITED WARRANTY at www.specmix.com/product-warranty or send a written request to SPEC MIX, LLC, Five Concourse Parkway, Atlanta, GA 30328, USA.

AVISO: Obtenga la GARANTÍA LIMITADA correspondiente en www.specmix.com/product-warranty

warranty o envíe una solicitud por escrito a SPEC MIX, LLC, Five Concourse Parkway, Atlanta, GA 30328, USA.

In Canada

NOTICE: Obtain the applicable LIMITED WARRANTY at www.specmix.com/product-warranty or send a written request to SPEC MIX, LLC, Five Concourse Parkway, Atlanta, GA 30328, USA.

AVIS: Obtenez la GARANTIE LIMITÉE applicable sur www.specmix.com/produit-garantie. Ou envoyez une demande écrite à SPEC MIX, LLC, Five Concourse Parkway, Atlanta, GA 30328, USA.

TECHNICAL SUPPORT

- CONTACT YOUR LOCAL SPEC MIX® MANUFACTURER
- VISIT WWW.SPECMIX.COM
- CONTACT SPEC MIX
- PHONE: 888-SPEC MIX FAX: 651-454-5315